

# The Harman Kardon Model T35

Manual No. 71A

## AUTO-LIFT TURNTABLE

# Technical Manual



T35

**harman/kardon**

240 CROSSWAYS PARK WEST, WOODBURY, N.Y. 11797  
1112-H15271A5 P-088312 1650 PRINTED IN JAPAN

## SPECIFICATIONS

Wow & Flutter (WRMS)	0.04%
Rumble (DIN-B WTD)	-68dB, DIN 45544 record reference
Pitch Adjustable Range	±3%
<b>Tonearm</b>	
Effective Tonearm Mass	8g (plus the mass of the cartridge used)
Stylus Overhang	18mm
Offset Angle	25.5°
Effective Length	216mm
Tracking Error	±2 degrees
Phono Capacitance	160pF
Tracking Force	0~3 grams

Acceptable Weight of Cartridge	3~8 g
Dimensions (W X H X D)	17-3/8" x 5-3/4" x 14-13/16" (440 x 145 x 375mm)
Weight	14 lbs. 7oz. (6.4kg)
<b>Power Supply</b>	
U.S.A. and Canada models	AC120V, 60Hz
General model	AC110-120V/220-240V, 50/60Hz
<b>Power Consumption</b>	8W

Specifications and components subject to change without notice.  
Overall performance will be maintained or improved.

## LEAKAGE TEST (FOR SERVICE ENGINEERS IN THE U.S.A.)

Before returning the unit to the user, perform the following safety checks:

1. Inspect all lead dress to make certain that leads are not pinched or that hardware is not lodged between the chassis and other metal parts in the unit.
2. Be sure that any protective devices such as nonmetallic control knobs, insulating fishpapers, cabinet backs, adjustment and compartment covers or shields, isolation resistor-capacity networks, mechanical insulators, etc. which were removed for servicing are properly reinstalled.
3. Be sure that no shock hazard exists; check for leakage current using Simpson Model 229 Leakage Tester, standard equipment item No. 21641, RCA Model WT540A or use alternate method as follows:

Plug the power cord directly into a 120-volt AC receptacle (do not use an Isolation Transformer for this test). Using two clip leads, connect a 1500 Ohm, 10-watt resistor paralleled by a 0.15 $\mu$ F capacitor, in series with all exposed metal cabinet parts and a known earth ground, such as a water pipe or conduit. Use a VTVM or VOM with 1000 Ohms per volt, or higher, sensitivity to measure the AC voltage drop across the resistor. (See Diagram.) Move the resistor connection to each exposed metal part having a return path to the chassis (antenna, metal, cabinet, screw heads, knobs and control shafts, escutcheon, etc.) and measure the AC voltage drop across the resistor. (This test should be performed with the power switch in both the On and Off positions.)

A reading of 0.35 volt RMS or more is excessive and indicates a potential shock hazard which must be corrected before returning the unit to the owner.

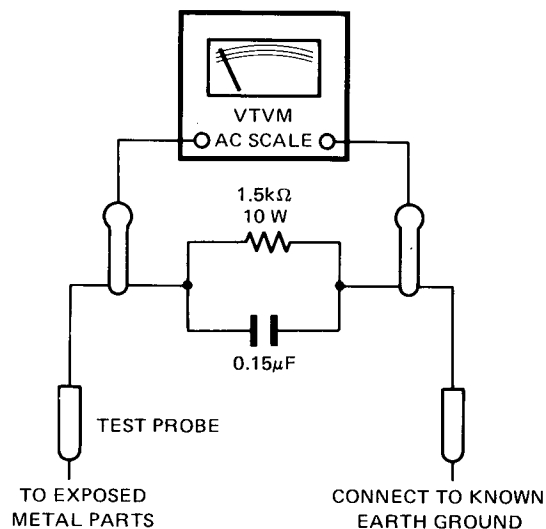
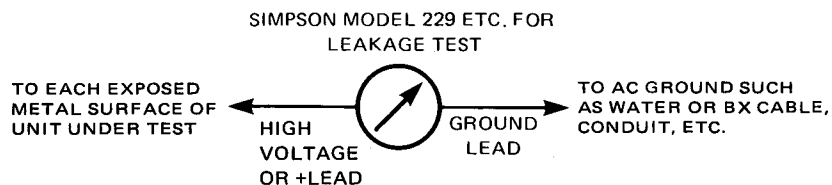

## CARTRIDGE REPLACEMENT INSTRUCTION

Only use cartridges in the headshell provided. Be sure to use a cartridge weighting 3 to 8 grams.

1. Release the tonearm clamp and lift the tonearm gently.
2. Loosen the headshell clamp and gently pull the headshell with cartridge. (See Fig. A.)
3. Disconnect the 4 leads from cartridge pins using a tweezers and then loosen the retaining screws so that the cartridge comes out.
4. Replace the leads onto the new cartridge. Refer to Fig. B for correct placement of leads.
5. When all leads are connected properly, install cartridge to the headshell as shown in the Fig. B.
6. Temporarily tighten the retaining screw to hold the cartridge.
7. Insert the headshell with the cartridge fully into the tonearm and then tighten the headshell clamp.

When cartridge is replaced with new one, it is necessary to adjust the Overhang and Tracking angle.

### ● Overhang Adjustment

1. Place the accessory tracking angle gauge on the center spindle and raise the flap.
2. Be sure to remove the stylus guard when adjusting the overhang.
3. Move the tonearm directly over the center spindle. Line up the raised flap on the gauge with the center spindle and the tonearm base. Gently move the cartridge backward or forward in the headshell so that the stylus tip lines up with the corner of the flap.

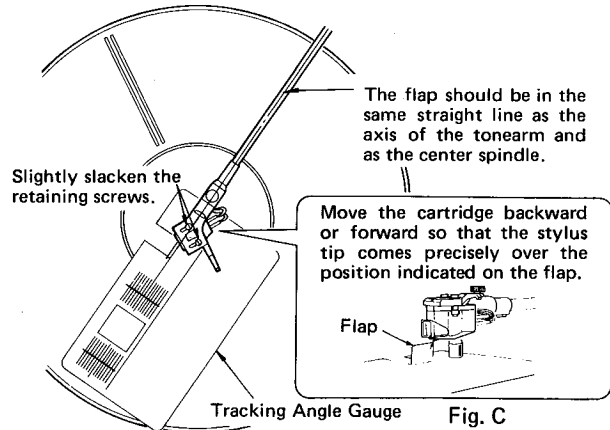
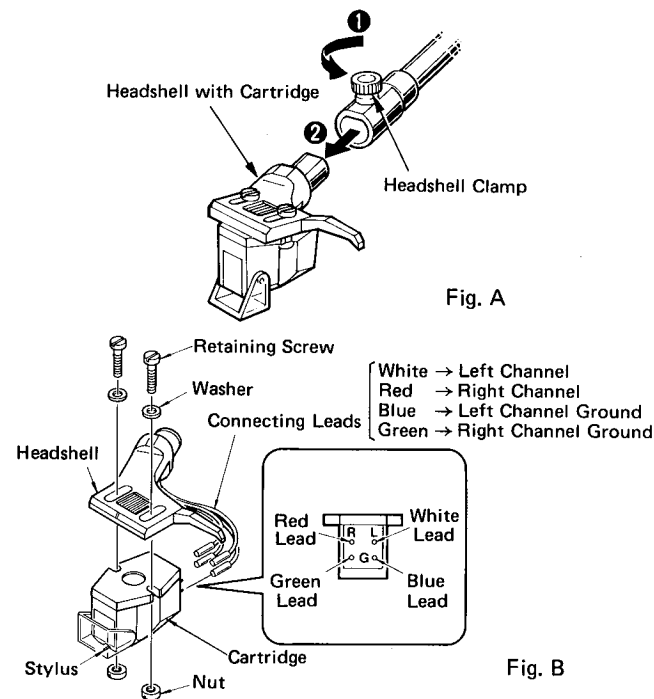

### ● Tracking Angle Adjustment

1. Check to be sure that the overhang adjustment has been completed.
2. Now move the tracking angle gauge until it is in the same position with respect to the tonearm as that shown in Fig. D. Place the stylus over the tracking angle setting point with keeping stylus guard attached.
3. Without changing the stylus position, turn the cartridge so that its front edge is parallel with the lines on the gauge.
4. Now move it so that it is in the position shown in Fig. E and check that the cartridge is still parallel with the parallel lines as it was in step 3 above. If it is not parallel, then repeat steps 3 and 4 alternately until the cartridge is parallel in both cases.
5. When the above adjustment is completed, then tighten the screws that attach the cartridge to the headshell fully.

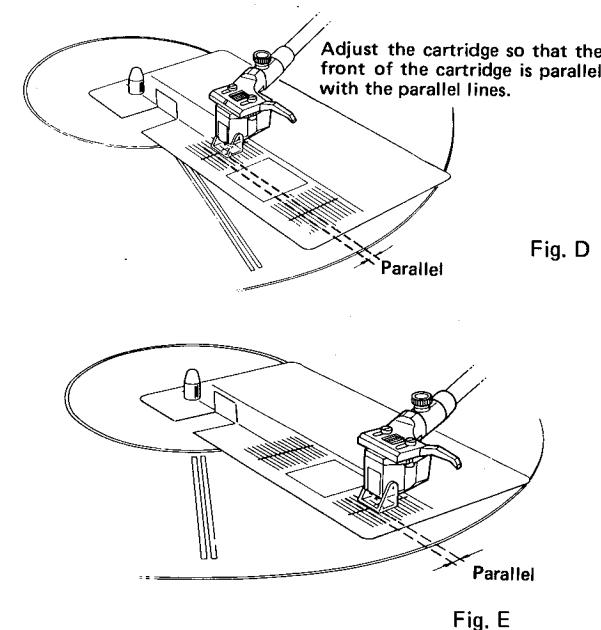

## ALIGNMENT PROCEDURES

### ■ DISC END DETECTION POSITION ADJUSTMENT

#### Conditions

- \* Be sure not to hang the drive belt between platter and motor pulley.
- \* Lift Switch. . . . . Auto

#### LP POSITION ADJUSTMENT

1. Set the speed selector to the 33 position.
2. Lower the cue lever. (Raising plate is set to the low position.)
3. By turning the adjustment screw of the forwarding arm assembly, adjust so that the stylus of cartridge detects the disc end position between 111.94mm ~ 107.2mm from the center of center spindle assembly.

#### EP POSITION ADJUSTMENT

1. Set the speed selector to the 45 position.
2. Lower the cue lever. (Raising plate is set to the low position.)
3. By turning the adjustment screw of the forwarding arm assembly, adjust so that the stylus of cartridge detects the disc end position between 102.74mm ~ 98.4mm from the center of center spindle assembly.

#### NOTE:

1. Turning the adjustment screw of the forwarding arm assembly clockwise makes a fast detection of the disc end position, and turning it counterclockwise makes slow detection.
2. If it is not within the rate, assumedly, it results from the attached position of forwarding arm assembly. Try to change the attached position by loosening the fixing screw also found on the forwarding arm assembly.
3. When the disc end position is detected, the tonearm will automatically lift up and the motor revolution will stop. If you are going to start it again, place the tonearm back on armrest.

### ■ MOTOR R.P.M. ADJUSTMENT

#### Instrument

Low Range Tachometer

#### Conditions

- \* Be sure that the drive belt between platter and motor pulley is hung.
- \* Flip the cue lever forward to lift the tonearm up.

1. Set the speed selector to the 33 position and set the speed control knob to the center position.
2. Move tonearm horizontally as to be level with the platter, and rotate the platter.
3. With the platter turning, adjust SVR201 so that the motor speed rating is within 33-1/3 r.p.m. ±1%, and then adjust SVR2011 so that the motor speed rating is within 33-1/3 r.p.m.
4. Set the speed selector to the 45 position.
5. With the platter turning, adjust SVR202 so that the motor speed rating is within 45 r.p.m. ±1%, and then adjust SVR2021 so that the motor speed rating is within 45 r.p.m.

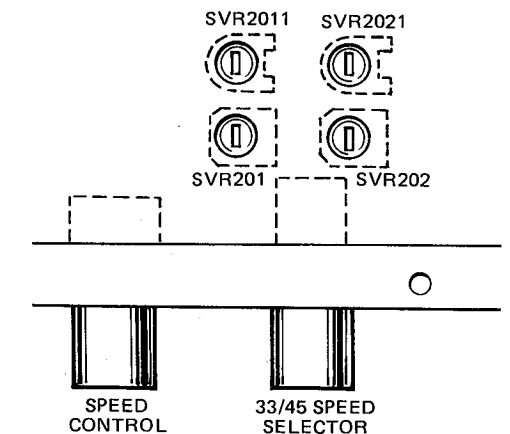
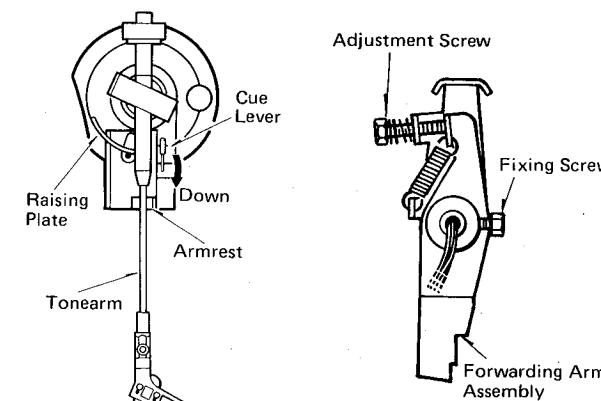
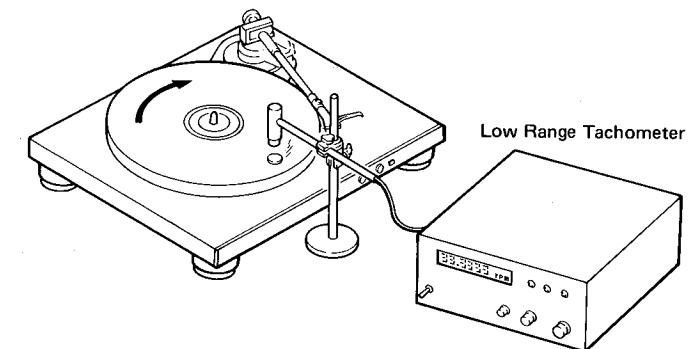

# CARTRIDGE REPLACEMENT INSTRUCTION

Only use cartridges in the headshell provided. Be sure to use a cartridge weighting 3 to 8 grams.

1. Release the tonearm clamp and lift the tonearm gently.
2. Loosen the headshell clamp and gently pull the headshell with cartridge. (See Fig. A.)
3. Disconnect the 4 leads from cartridge pins using a tweezers and then loosen the retaining screws so that the cartridge comes out.
4. Replace the leads onto the new cartridge. Refer to Fig. B for correct placement of leads.
5. When all leads are connected properly, install cartridge to the headshell as shown in the Fig. B.
6. Temporarily tighten the retaining screw to hold the cartridge.
7. Insert the headshell with the cartridge fully into the tonearm and then tighten the headshell clamp.

When cartridge is replaced with new one, it is necessary to adjust the Overhang and Tracking angle.

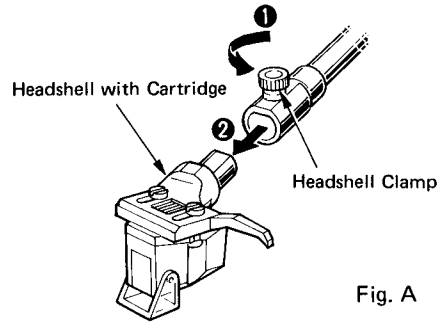

Fig. A

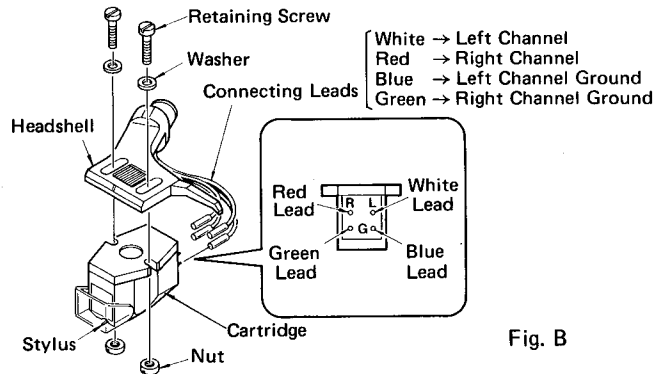

Fig. B

## ● Overhang Adjustment

1. Place the accessory tracking angle gauge on the center spindle and raise the flap.
2. Be sure to remove the stylus guard when adjusting the overhang.
3. Move the tonearm directly over the center spindle. Line up the raised flap on the gauge with the center spindle and the tonearm base. Gently move the cartridge backward or forward in the headshell so that the stylus tip lines up with the corner of the flap.

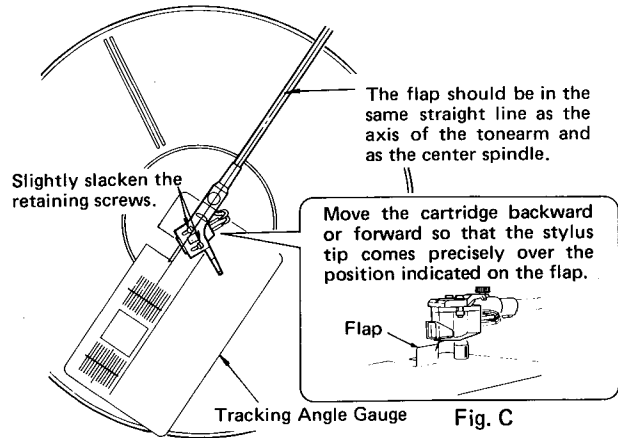

Fig. C

## ● Tracking Angle Adjustment

1. Check to be sure that the overhang adjustment has been completed.
2. Now move the tracking angle gauge until it is in the same position with respect to the tonearm as that shown in Fig. D. Place the stylus over the tracking angle setting point with keeping stylus guard attached.
3. Without changing the stylus position, turn the cartridge so that its front edge is parallel with the lines on the gauge.
4. Now move it so that it is in the position shown in Fig. E and check that the cartridge is still parallel with the parallel lines as it was in step 3 above. If it is not parallel, then repeat steps 3 and 4 alternately until the cartridge is parallel in both cases.
5. When the above adjustment is completed, then tighten the screws that attach the cartridge to the headshell fully.

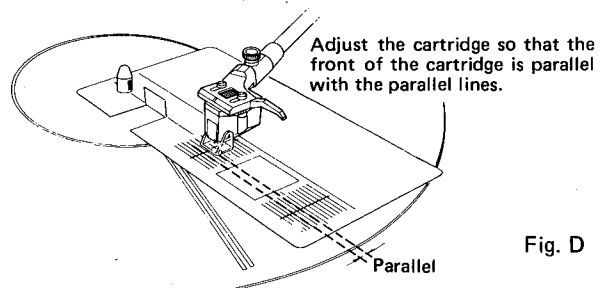

Fig. D

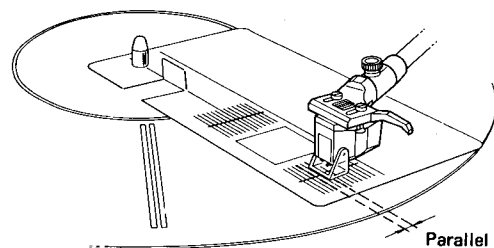

Fig. E

## ALIGNMENT PROCEDURES

### ■ DISC END DETECTION POSITION ADJUSTMENT

**Conditions**

- \*Be sure not to hang the drive belt between platter and motor pulley.
- \*Lift Switch. . . . . Auto

### LP POSITION ADJUSTMENT

1. Set the speed selector to the 33 position.
2. Lower the cue lever. (Raising plate is set to the low position.)
3. By turning the adjustment screw of the forwarding arm assembly, adjust so that the stylus of cartridge detects the disc end position between 111.94mm ~ 107.2mm from the center of center spindle assembly.

### EP POSITION ADJUSTMENT

1. Set the speed selector to the 45 position.
2. Lower the cue lever. (Raising plate is set to the low position.)
3. By turning the adjustment screw of the forwarding arm assembly, adjust so that the stylus of cartridge detects the disc end position between 102.74mm ~ 98.4mm from the center of center spindle assembly.

**NOTE:**

1. Turning the adjustment screw of the forwarding arm assembly clockwise makes a fast detection of the disc end position, and turning it counterclockwise makes slow detection.
2. If it is not within the rate, assumedly, it results from the attached position of forwarding arm assembly. Try to change the attached position by loosening the fixing screw also found on the forwarding arm assembly.
3. When the disc end position is detected, the tonearm will automatically lift up and the motor revolution will stop. If you are going to start it again, place the tonearm back on armrest.

### ■ MOTOR R.P.M. ADJUSTMENT

**Instrument**

Low Range Tachometer

**Conditions**

- \* Be sure that the drive belt between platter and motor pulley is hung.
- \* Flip the cue lever forward to lift the tonearm up.

1. Set the speed selector to the 33 position and set the speed control knob to the center position.
2. Move tonearm horizontally as to be level with the platter, and rotate the platter.
3. With the platter turning, adjust SVR201 so that the motor speed rating is within 33-1/3 r.p.m. ±1%, and then adjust SVR2011 so that the motor speed rating is within 33-1/3 r.p.m.
4. Set the speed selector to the 45 position.
5. With the platter turning, adjust SVR202 so that the motor speed rating is within 45 r.p.m. ±1%, and then adjust SVR2021 so that the motor speed rating is within 45 r.p.m.

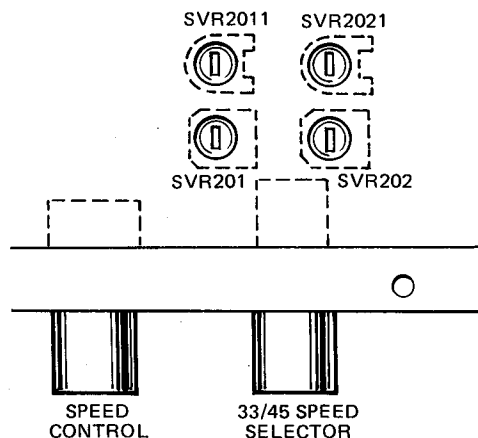
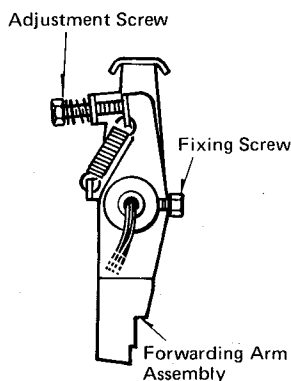
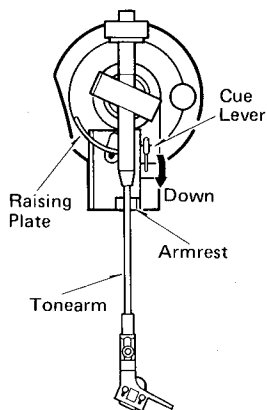
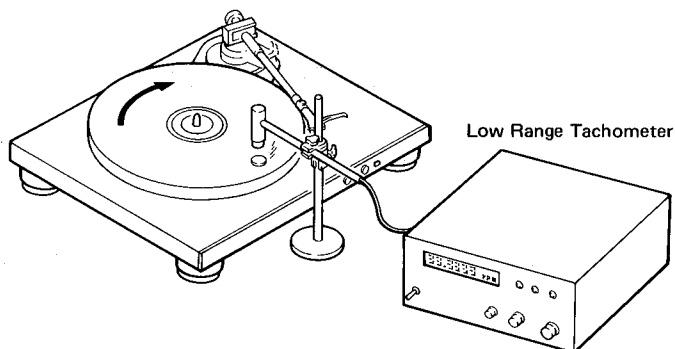

## DISASSEMBLY PROCEDURES (REFER TO PAGES 6 AND 11)

### 1 MAIN P.C. BOARD (PCB-1) REMOVAL

1. Remove 5 screws **A** and remove the Bottom Cover B (29).
2. Remove 2 screws **B** and remove the Main P.C. Board (PCB-1) with Bracket (39). If necessary, unsolder the lead wires.

### 2 FRONT PANEL ASSEMBLY (2) REMOVAL

1. Remove the Main P.C. Board (PCB-1). (Refer to step 1.)
2. Remove 3 screws **C** mounting Front Panel Assembly (2) and remove it.

### 3 MOTOR ASSEMBLY (MO1) REMOVAL

1. Remove 5 screws **D** and 2 hexagon nuts **E** and remove the Bottom Cover A (20) with Power Transformer (T1).
2. Remove 2 hexagon nuts **F** and remove the Motor Assembly (MO1) with the Motor Bracket (17). If necessary, unsolder the lead wires.

### 4 POWER TRANSFORMER (T1) REMOVAL

1. Remove the Bottom Cover A (20). (Refer to step 3-1.)
2. Remove 2 screws **G** and remove the Power Transformer (T1).

### 5 PICK-UP ASSEMBLY (3) REMOVAL

1. Remove 6 screws **H** and remove Bottom Cover C (30).
2. Unsolder the pick-up leads from Terminal Strip (TE1).
3. Loosen the fixing screw **I** of the Forwarding Arm Assembly (11).
4. Remove the screw **J** on the Pick-Up Base Assembly (4) and then pull out Pick-Up Assembly (3) upward from Pick-Up Base Assembly (4).

### 6 PICK-UP BASE ASSEMBLY (4) REMOVAL

1. Remove the Pick-Up Assembly (3). (Refer to step 5.)
2. Remove 2 screws **K** and remove the Micro Switch (SW1).
3. Remove 2 screws **L** and remove the Sensor Assembly (SE1).
4. Remove 4 screws **M** and remove the Pick-Up Base Assembly (4).

## POWER CORD REPLACEMENT (FOR SERVICE ENGINEERS OTHER THAN NORTH AMERICA)

In order to prevent fire or shock hazard when replacing the power cord, follow the procedure below to replace the parts with the standard supply parts.

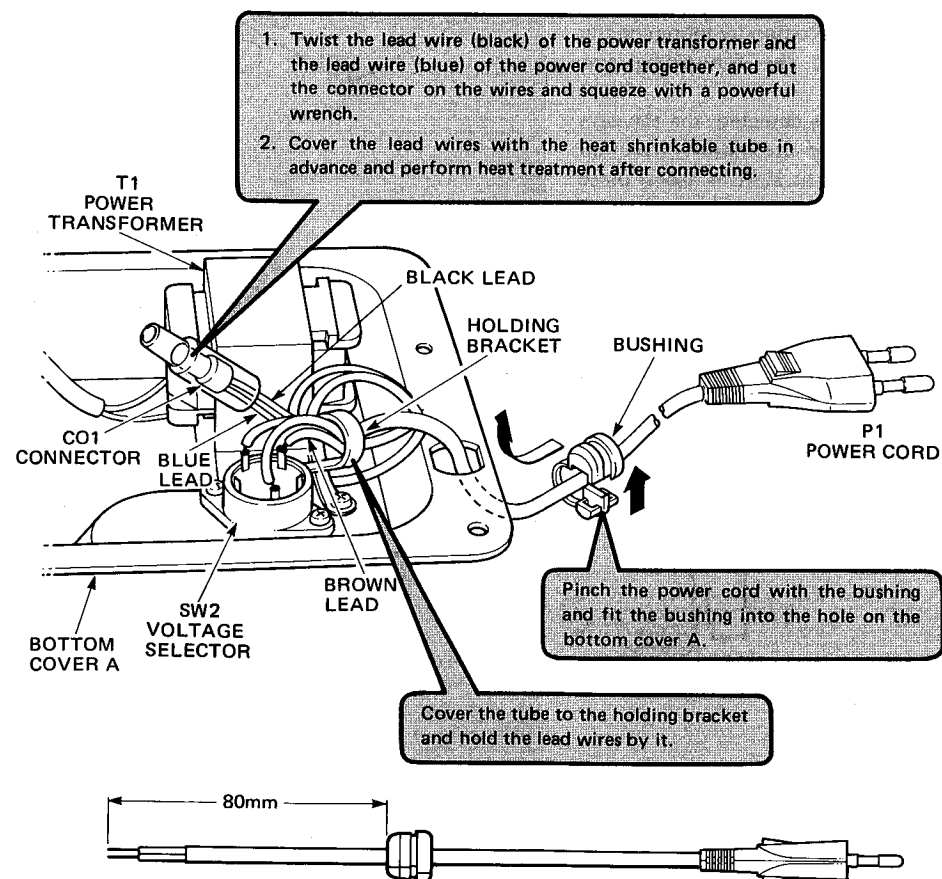

## GENERAL UNIT EXPLODED VIEW

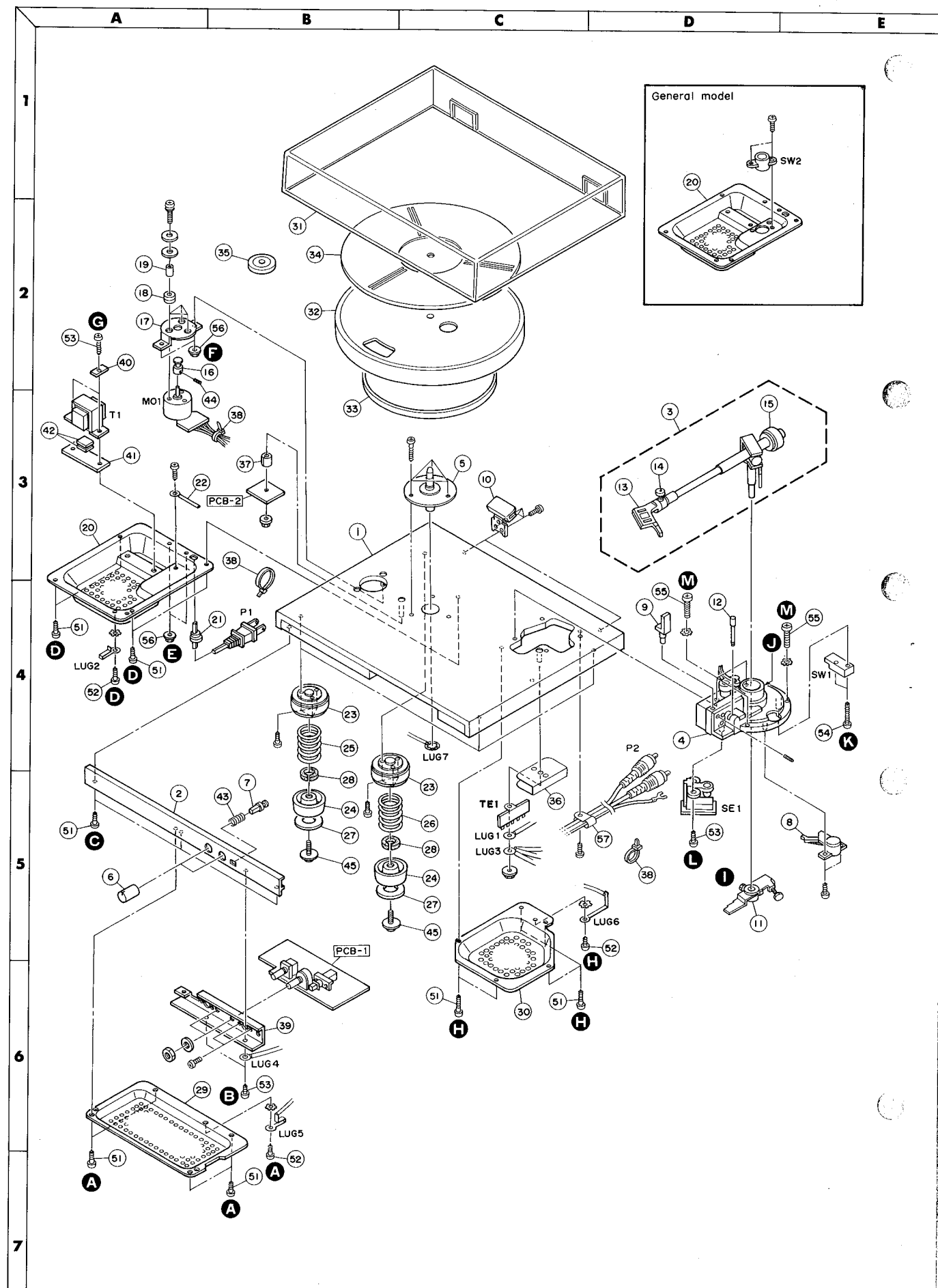

## DISASSEMBLY PROCEDURES (REFER TO PAGES 6 AND 11)

### 1 MAIN P.C. BOARD (PCB-1) REMOVAL

1. Remove 5 screws **A** and remove the Bottom Cover B (29).
2. Remove 2 screws **B** and remove the Main P.C. Board (PCB-1) with Bracket (39). If necessary, unsolder the lead wires.

### 2 FRONT PANEL ASSEMBLY (2) REMOVAL

1. Remove the Main P.C. Board (PCB-1). (Refer to step 1.)
2. Remove 3 screws **C** mounting Front Panel Assembly (2) and remove it.

### 3 MOTOR ASSEMBLY (MO1) REMOVAL

1. Remove 5 screws **D** and 2 hexagon nuts **E** and remove the Bottom Cover A (20) with Power Transformer (T1).
2. Remove 2 hexagon nuts **F** and remove the Motor Assembly (MO1) with the Motor Bracket (17). If necessary, unsolder the lead wires.

### 4 POWER TRANSFORMER (T1) REMOVAL

1. Remove the Bottom Cover A (20). (Refer to step 3-1.)
2. Remove 2 screws **G** and remove the Power Transformer (T1).

### 5 PICK-UP ASSEMBLY (3) REMOVAL

1. Remove 6 screws **H** and remove Bottom Cover C (30).
2. Unsolder the pick-up leads from Terminal Strip (TE1).
3. Loosen the fixing screw **I** of the Forwarding Arm Assembly (11).
4. Remove the screw **J** on the Pick-Up Base Assembly (4) and then pull out Pick-Up Assembly (3) upward from Pick-Up Base Assembly (4).

### 6 PICK-UP BASE ASSEMBLY (4) REMOVAL

1. Remove the Pick-Up Assembly (3). (Refer to step 5.)
2. Remove 2 screws **K** and remove the Micro Switch (SW1).
3. Remove 2 screws **L** and remove the Sensor Assembly (SE1).
4. Remove 4 screws **M** and remove the Pick-Up Base Assembly (4).

## POWER CORD REPLACEMENT (FOR SERVICE ENGINEERS OTHER THAN NORTH AMERICA)

In order to prevent fire or shock hazard when replacing the power cord, follow the procedure below to replace the parts with the standard supply parts.

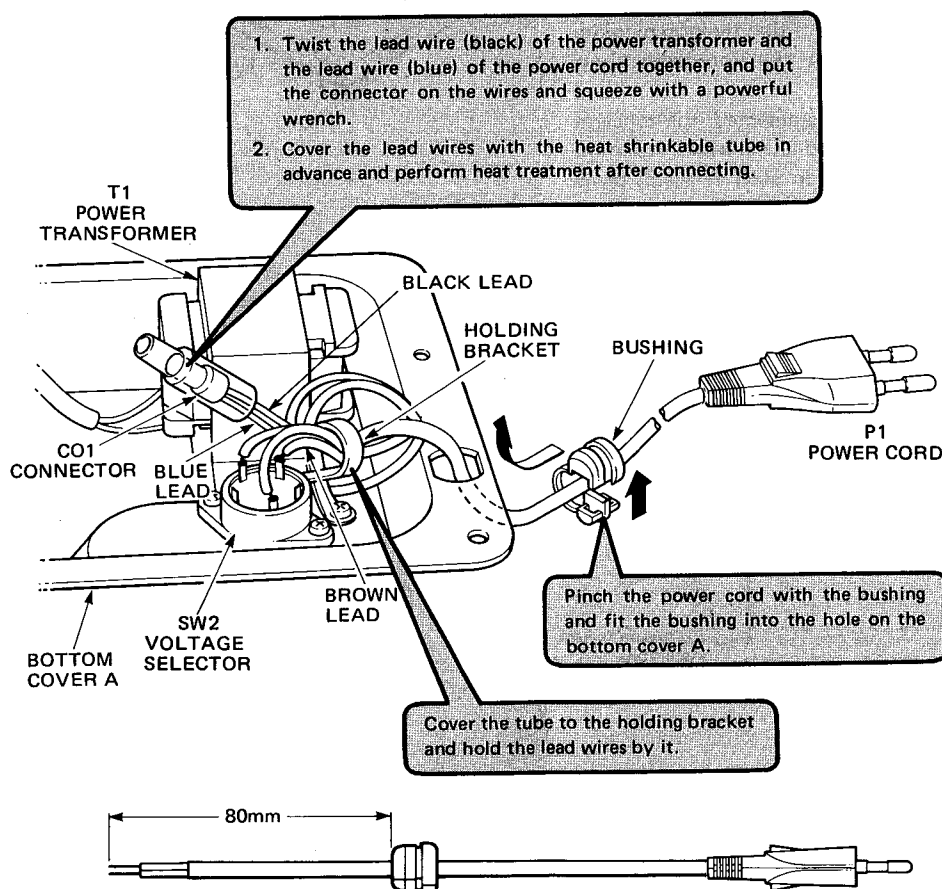

# GENERAL UNIT EXPLODED VIEW

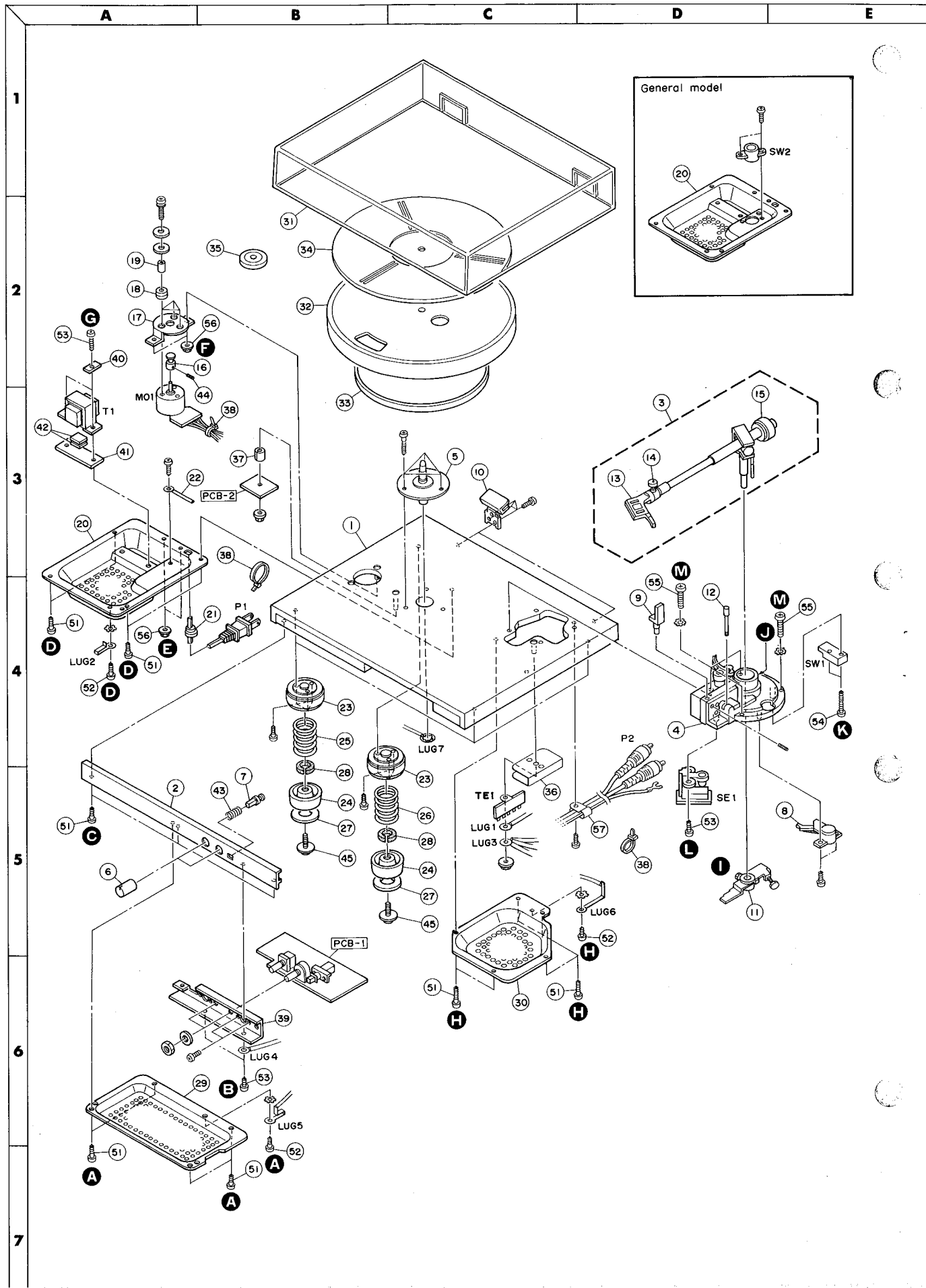



## GENERAL UNIT PARTS LIST

Ref. No.	Part No.	Description
1	A415-T35A	Cabinet Assembly (for U.S.A. and Canada models)
	A415-T35B	Cabinet Assembly (for General model)
2	A443-T35	Front Panel Assembly
3	A371-T35	Pick-Up Assembly (without Cartridge and Stylus)
4	A562-T35	Pick-Up Base Assembly
5	2601-7108	Center Spindle Assembly
6	A634-T35A	Knob Assembly, 33/45 Speed Selector, Speed Control
7	A660-T35	Push Button Assembly, Lift
8	A634-T35B	Anti-Skating Control Assembly
9	912285	Armrest Assembly
10	910557-1	Hinge Assembly
11	911451-1	Forwarding Arm Assembly
12	912200	Cue Lever
13	852366S	Headshell
14	852366A	Headshell Clamp
15	852366W	Counterweight
16	894021	Motor Pulley
17	912205	Motor Bracket
18	242020	Bushing
19	915204	Sleeve
20	853236	Bottom Cover A (for U.S.A. and Canada models)
	853236-1	Bottom Cover A (for General model)
21	891568-5	Bushing
22	890755	Holding Bracket
23	914901	Foot
24	914902	Foot
25	914960	Spring
26	914960-1	Spring
27	914961	Felt
28	914994	Absorber
29	873952	Bottom Cover B
30	873953	Bottom Cover C
31	852682	Dust Cover
32	620107	Platter
33	700515B	Drive Belt
34	2115-00102	Platter Mat
35	912286	45 RPM Adaptor
36	890959-1	Shield Plate
37	897342-1	Spacer
38	894408	Holder, Lead Wire
39	873949	Bracket
40	915132	Bracket
41	915121	Bracket
42	915122	Plate
43	2651-210189	Spring
44	Y13200301	Screw (-) (2 x 3mm)
45	912290	Foot Screw
51	Y08301207	Self-Tapping Screw (+) (3 x 12mm)
52	Y10300601	Screw (+) (3 x 6mm)
53	Y10300801	Screw (+) (3 x 8mm)
54	Y10262001	Screw (+) (2.6 x 20mm)
55	Y03301802	Screw (+) (3 x 18mm)
56	Y22000302	Hexagon Nut
57	911466	Holder

## ELECTRICAL PARTS LIST

Ref. No.	Part No.	Description
<b>CHASSIS MISCELLANEOUS</b>		
△ P1	892435	Power Cord (for U.S.A. & Canada models)
△ P1	895617-2	Power Cord (for General model)
P2	915009	Output Cord Assembly
△ T1	873950-1	Power Transformer (for U.S.A. & Canada models)
△ T1	873982	Power Transformer (for General model)
△ CO1, 2	913142-1	Connector, Power Cord
SW1	895430-1	Micro-Switch, Rest
△ SW2	898256-5	Rotary Switch, Voltage Selector (General model only)
MO1	707718002	Motor Assembly
SE1	D551-T35	Senser Assembly, Auto-Lift
L1	N.A. Separately	Solenoid, Auto-Lift (Part of Pick-Up Base Assembly)
TE1	890979	Terminal Strip
LUG1	914359-4	Lug Terminal with Lead Wire
LUG2	915205	Lug Terminal
LUG3/4/5/6/7	915134	Lug Terminal Assembly
<b>PCB-1 MAIN P.C. BOARD</b>		
<b>RESISTORS</b>		
R212	Z4054030A	270Ω, ±5%, 1W, Metal
<b>CONTROLS</b>		
VR201	910746-2	Variable Resistor, 5kΩB, Speed Control
SVR201	Z4060071	Semi-Variable Resistor, 50kΩB
SVR202	Z4060018	Semi-Variable Resistor, 20kΩB
SVR2011, 2021	Z4060070	Semi-Variable Resistor, 2kΩB
<b>CAPACITORS</b>		
C201	5345-108-35	1000μF, ±20%, 35V, Electrolytic
C202	5345-475-50	4.7μF, ±20%, 50V, Electrolytic
C205	5345-477-25	470μF, ±20%, 25V, Electrolytic
C206	5345-225-50	2.2μF, ±20%, 50V, Electrolytic
C207	5345-476-25	47μF, ±20%, 25V, Electrolytic
C208	5345-475D0951	4.7μF, ±20%, 25V, Electrolytic
<b>TRANSISTORS</b>		
X201, 202, 204, 205	Z4104103	2SC945(Q) or 2SC945(P) or 2SC945(K)
X203	Z4106132	2SD882(P)
<b>DIODES</b>		
D201	Z4110011	F14A
D202, 203	Z4110111	1S953
ZD201	Z4112112	Zener, RD12EB3
<b>MISCELLANEOUS</b>		
SCR201	Z4115021	Silicon Controlled Rectifier, 03P05M
SW202	873404-1	Rotary Switch, 33/45 Speed Selector
SW204	911590-1	Push Switch, Lift
<b>PCB-2 POWER SUPPLY P.C. BOARD</b>		
△ D204	Z4110041	Bridge Silicon Diode, S1VB10
△ FU201	704395-5	Fuse, 1.25A 250V (for U.S.A. and Canada models)
△ FU201	893791-3	Fuse, T800mA 250V (for General model)
CNP1	706033-2	Connector, 2 Pos.
△	893395-1	Fuse Holder (for U.S.A. and Canada models)
△	893395	Fuse Holder (for General model)

△ SAFETY RELATED COMPONENT. USE ONLY EXACT REPLACEMENT PART AS SPECIFIED.

**PACKAGE**

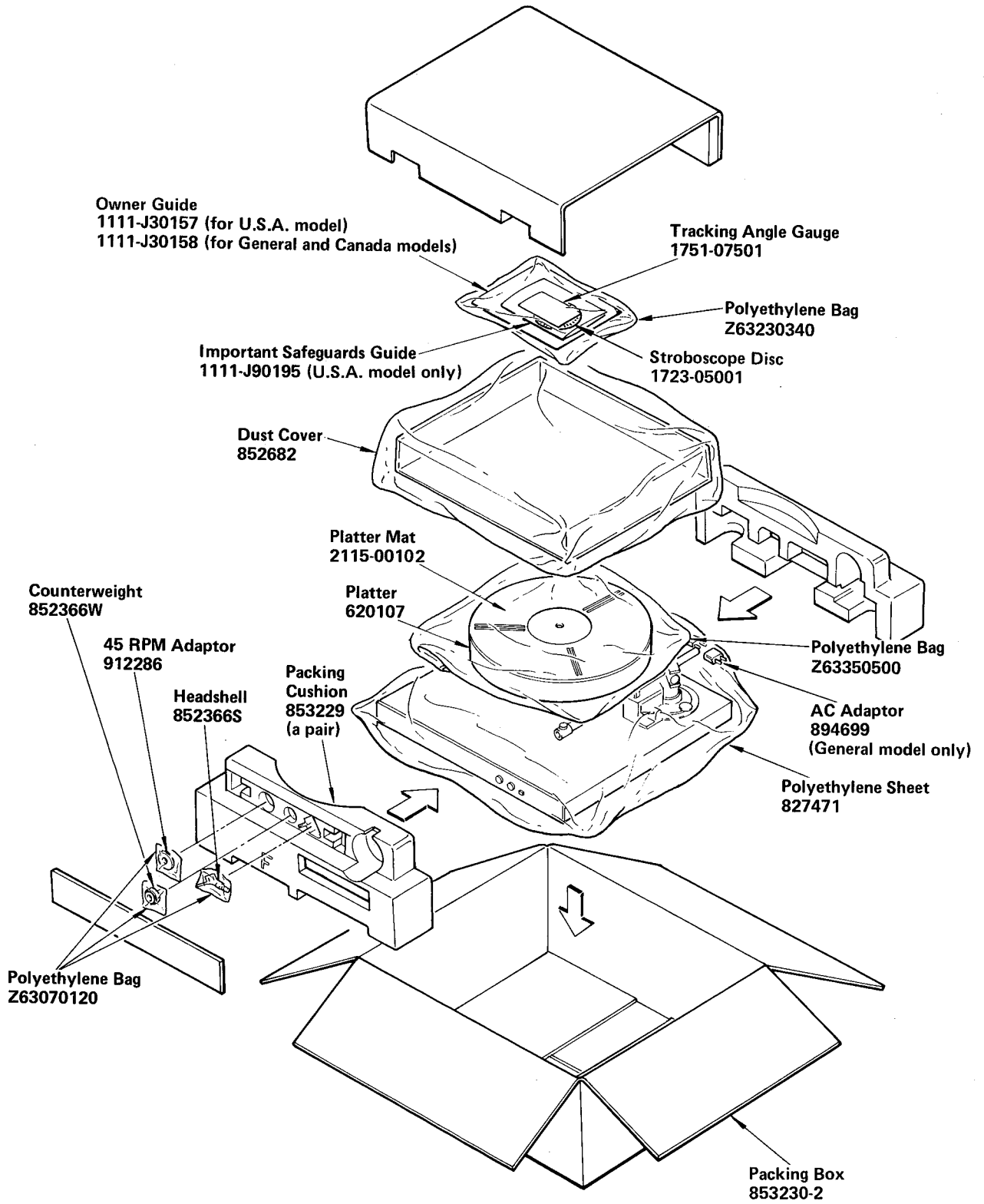



**SCHEMATIC DIAGRAM**

**General Model**

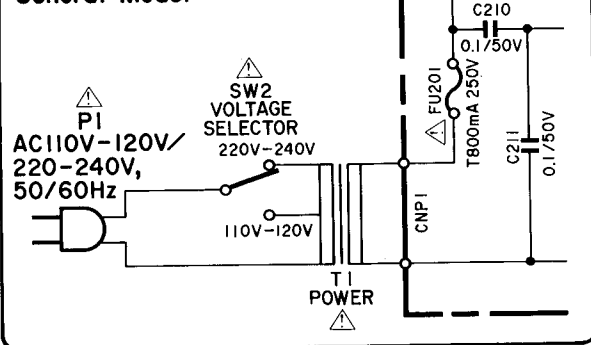

**PICK-UP ASSEMBLY**

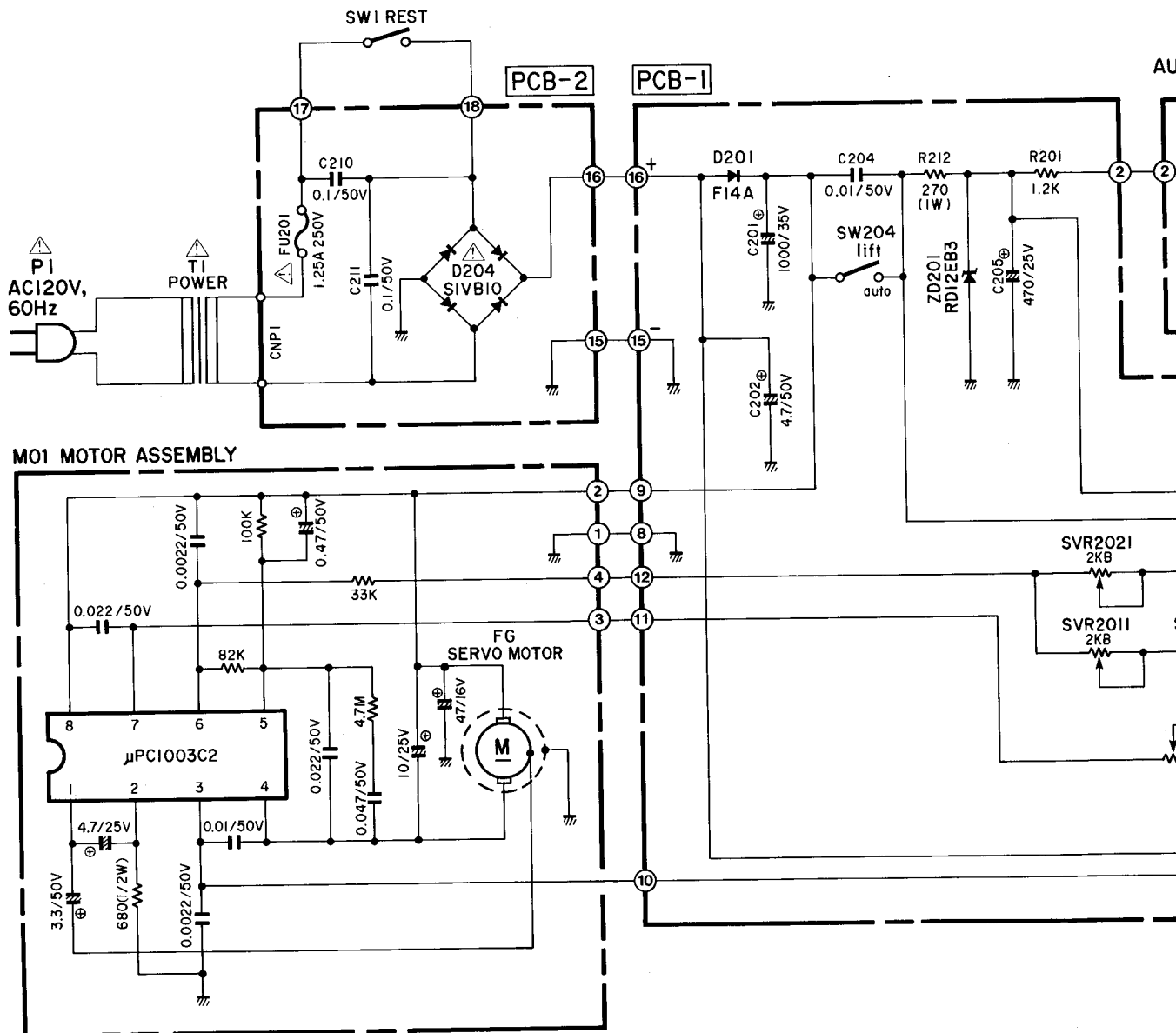
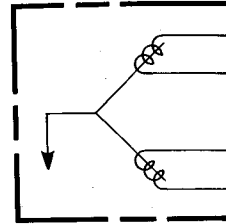

1

2

3

4

5

6

7

E	F	G	H	I	J
---	---	---	---	---	---

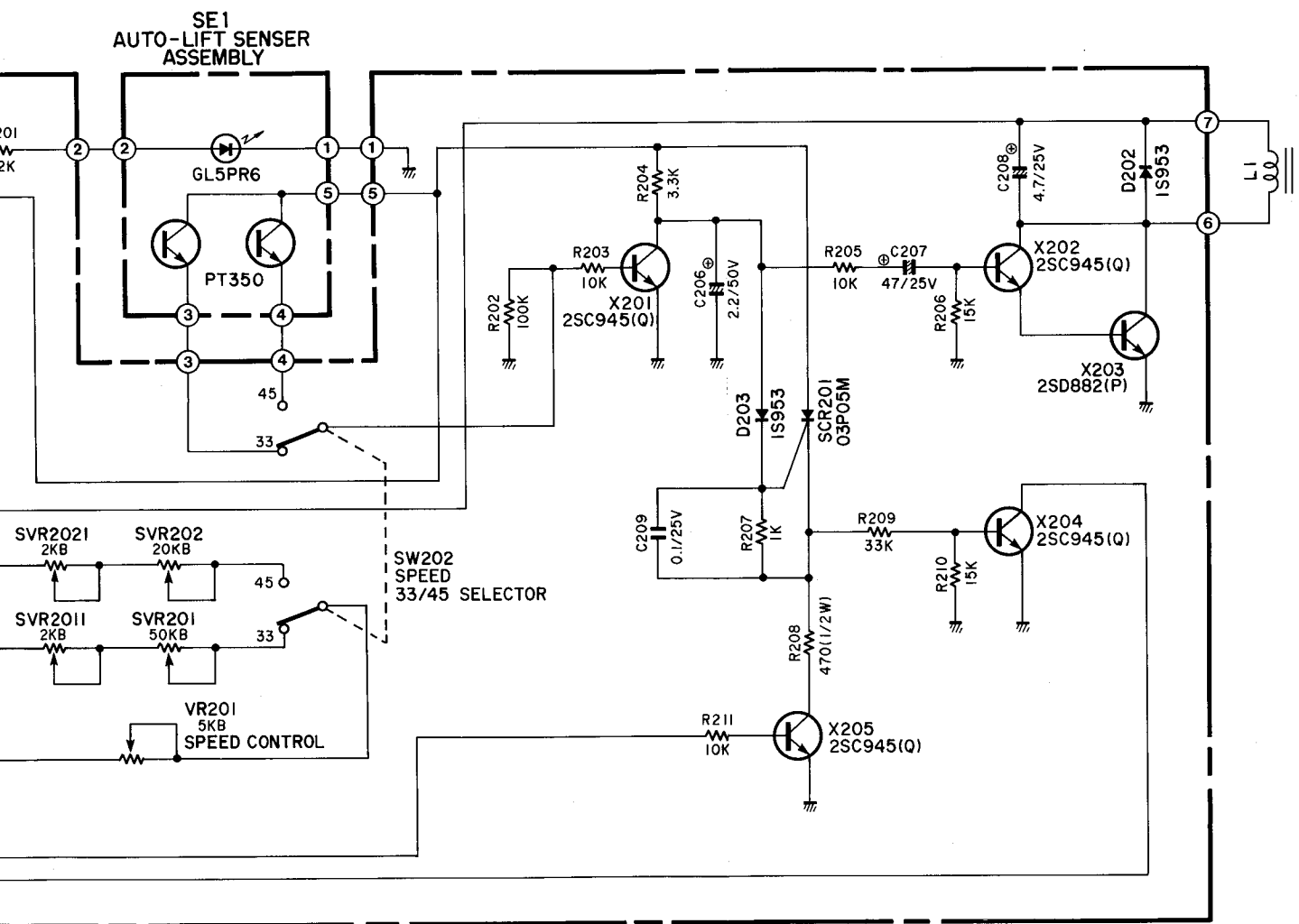
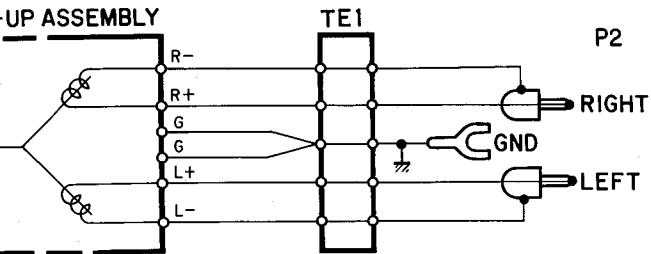

1. ALL RESISTANCES VALUES ARE IN  $\Omega$ .  
 $k\Omega = 1000\Omega$ ,  $M\Omega = 1000k\Omega$
2. THE WATTAGE OF RESISTORS IS 1/4W, UNLESS OTHERWISE NOTED.
3. ALL CAPACITANCES VALUES ARE IN  $\mu F$  UNLESS OTHERWISE NOTED. P =  $\mu\mu F$
4. SAFETY-REQUIREMENTS COMPONENTS IN ACCORDANCE WITH PRESENT SAFETY REGULATIONS, THESE COMPONENTS MUST ONLY BE REPLACED BY ORIGINAL PARTS.



WIRING DIAGRAM

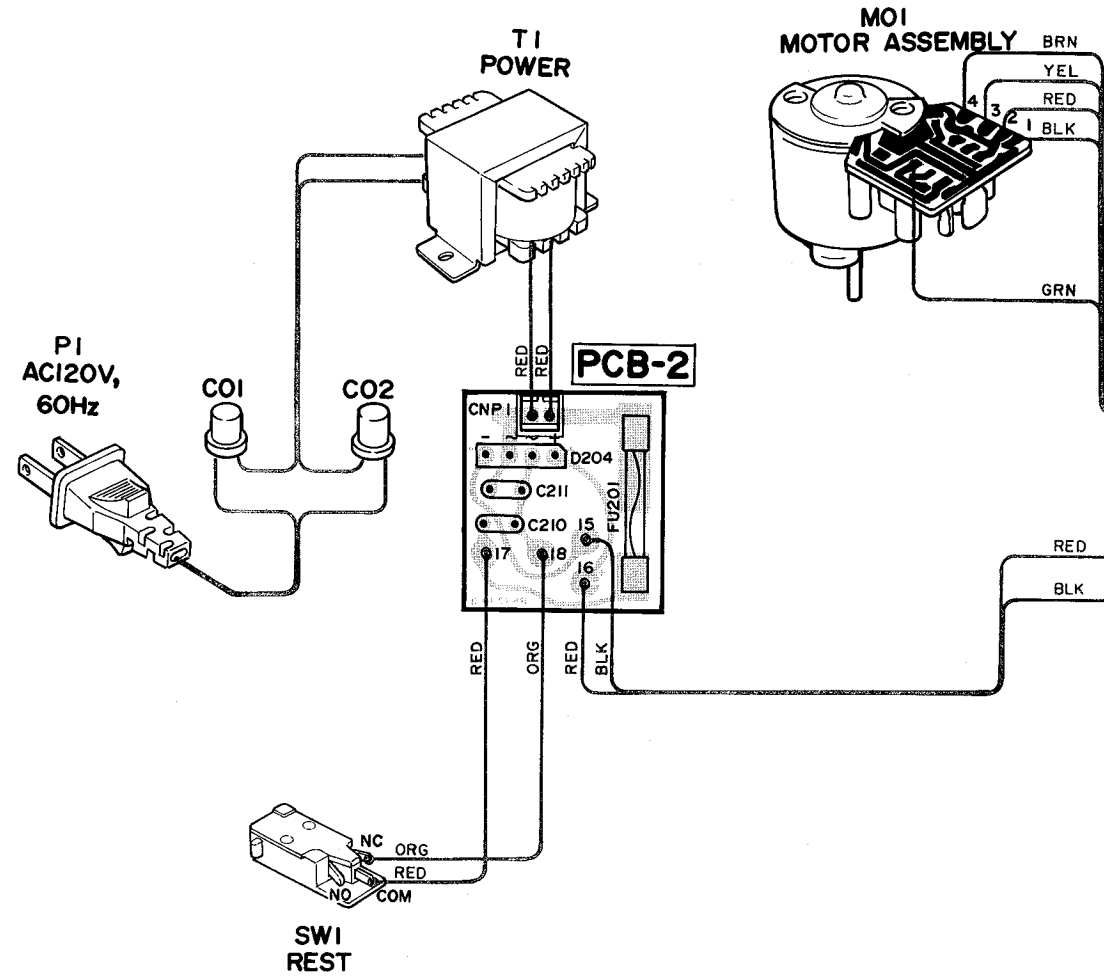
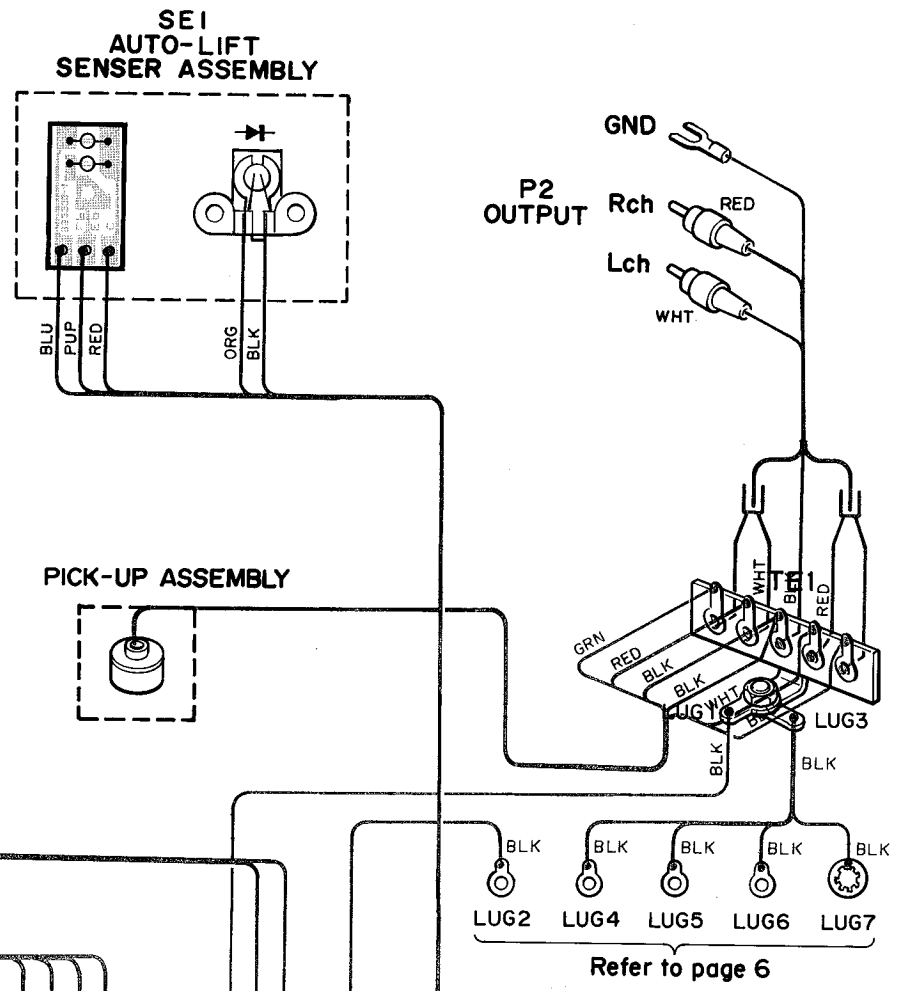
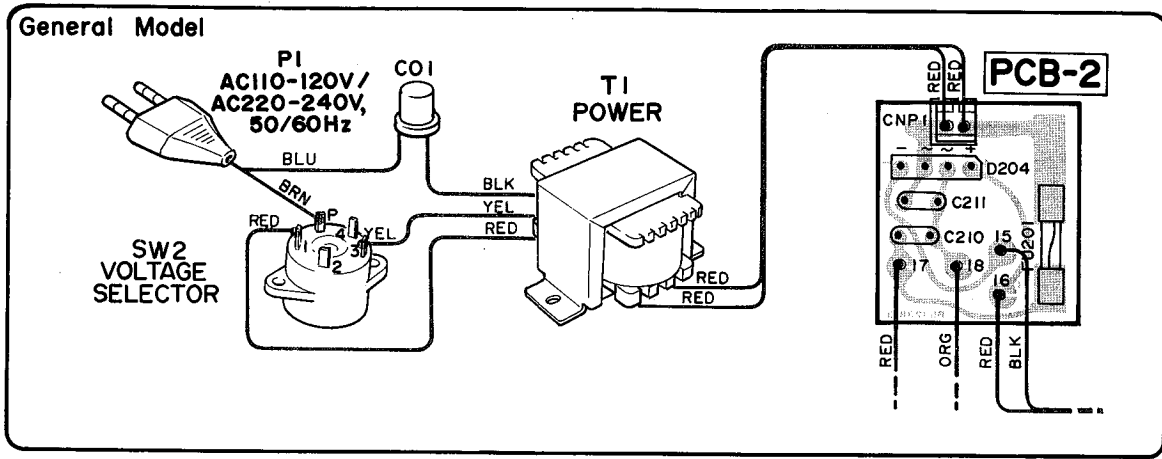

PIN CONNECTION DIAGRAM OF TRANSISTORS AND DIODES.

<p>2SC945(Q) or (P) or (K)</p>	<p>2SD882(P)</p>	<p>GL5PR6</p> <p>Cathode Anode</p>	<p>PT350</p>	<p>F14A</p> <p>Anode Cathode</p>	<p>1S953, RD12EB3</p> <p>Anode Cathode</p>	<p>S1VB10</p>
--------------------------------	------------------	------------------------------------	--------------	----------------------------------	--	---------------

- WIRE COLOR ABBREVIATIONS
- RED : Red
  - ORG : Orange
  - BLU : Blue
  - WHT : White
  - GRN : Green
  - BLK : Black
  - YEL : Yellow
  - PUP : Purple
  - PIK : Pink

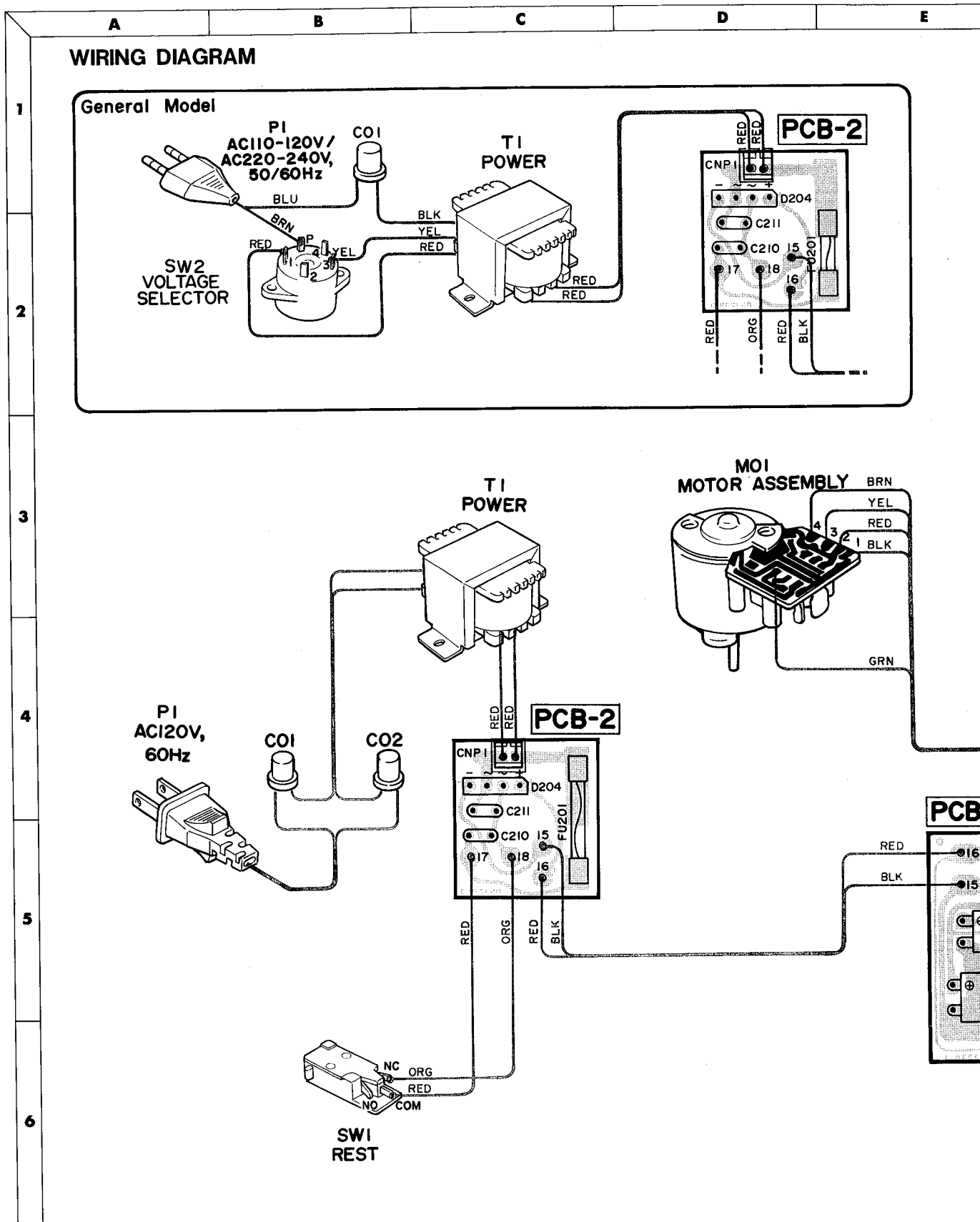

**PIN CONNECTION DIAGRAM OF TRANSISTORS AND DIODES.**

<p>2SC945(Q) or (P) or (K)</p>	<p>2SD882(P)</p>	<p>GL5PR6</p> <p>Cathode</p> <p>Anode</p>	<p>PT350</p>	<p>F14A</p> <p>Anode</p> <p>Cathode</p>	<p>1S953, RD12EB3</p> <p>Anode</p> <p>Cathode</p>	<p>S1VB10</p>
--------------------------------	------------------	---	--------------	---	---	---------------



### SEI AUTO-LIFT SENER ASSEMBLY

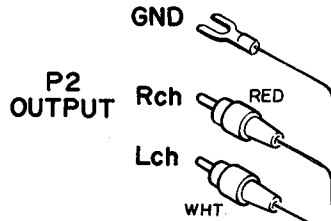
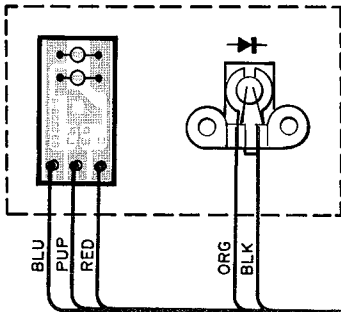

### PICK-UP ASSEMBLY



### LI SOLENOID

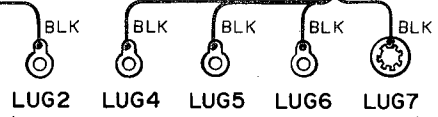
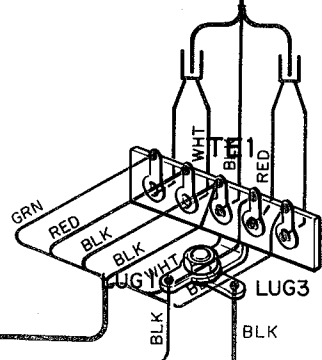
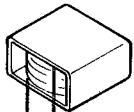

Refer to page 6

### PCB-1

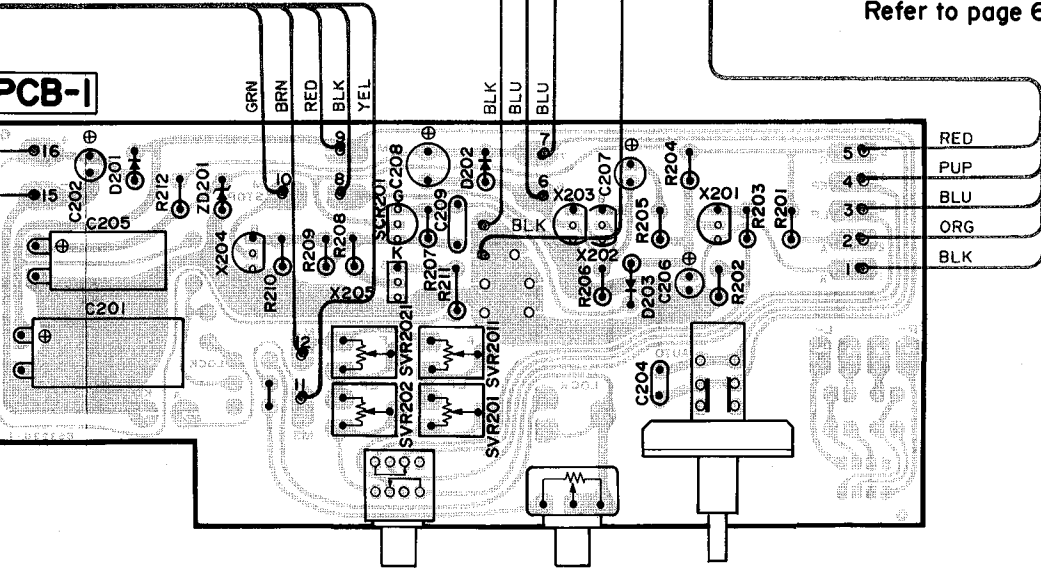

SW202  
33/45

VR201  
Control

SW204  
manual  
auto

SPEED

lift

#### ● WIRE COLOR ABBREVIATIONS

- RED : Red
- ORG : Orange
- BLU : Blue
- WHT : White
- GRN : Green
- BLK : Black
- YEL : Yellow
- PUP : Purple
- PIK : Pink